



Product Information

**STRATOS
Compact**

SL 2.0

Stand-on Powered Pallet Truck

The SL 2.0 powered pallet truck is designed for intensive applications, with a stand-in driver compartment. Suitable for loading/unloading applications and long transport distances. Rated capacity of 2000kg.



- The chassis width is only 770mm which provides exceptionally manoeuvrability in loading/unloading applications.
- Transversely standing driver gives the best and most comfortable driving position in both directions of travel.
- 195° steering. Forward/backward with the thumb, with automatic speed reduction. Additional brake function in a separate press button.
- Programmable performance — acceleration rate, maximum travel speed, current limitation, automatic speed reduction, plug braking (braking force by changing travel direction), speed control sensitivity and steering sensitivity.
- Electronic fault diagnosis with a series of error and caution codes to alert the driver and, if necessary, reduce operating speed or stop the truck.
- All electrical and mechanical components easily accessible for servicing and troubleshooting.
- Electronic steering system. Ergonomically designed control console with the steering wheel module with the steering wheel placed to the left. Requires minimum effort whatever the load.
- Extra high lift height — 235mm — for handling of roll cages. Easy loading/unloading on gradients or uneven surfaces.
- Battery exchange by lifting the battery out of the compartment.
- Unique swing axle design for castor and drive wheel in order to provide excellent stability and traction, even when working on ramps and slopes.

Options

- **Writing table**
Foldable. For A4-size paper.
- **Cold store version**
For operation in low temperatures.
- **Lever for lift/lowering**
Standard for lift/lowering function is push button.
- **Battery exchange sideways**
The battery is mounted on rollers, allowing easy access for inspection and also facilitating fast battery changes.

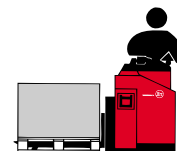

Technical Details		SL 2.0	Dimensions	mm	
Operating type		stand on/ride on	x	Front axle to fork face	958 ¹⁾
Rated capacity	kg	2000	y	Wheel base	1558 ¹⁾
Load centre	mm	600	h ₁₃	Height of lowered fork	85
Max axle pressure supp.wheel, without/with rated load	kg	225/1750	l ₂	Truck length incl. back of fork	874
Max axle pressure castor/drive wheel, without/with rated load	kg	770/1210	b ₁	Chassis, width	770
Service-/parking brake		2 stage electro-magnetic brake	l	Fork length	1000/1150/ 1450/2350
Travel speed, without/with rated load	km/h	10.5/8	e	Fork width	180
Lift speed, without/with rated load	m/s	0.07/0.05	b ₅	Width across fork	450/520/550/685
Lowering speed, without/with rated load	m/s	0.054/0.054	m ₁	Floor clearance	100
Gradient, without/with rated load	%	18/8	A _{st}	Aisle width, min	2274 ¹⁾
Drive motor/Intermittent rating	kW/%	2.2/60	W _a	Turning radius	1855 ¹⁾
Lift motor/Intermittent rating	kW/%	2.0/20	h ₃	Lift height	235
Weight without battery	kg	638	h ₇	Instep height	254
Battery (5h discharge), min./max.	Ah	300—450		Castor wheels, Vulkollan	Ø150x40
Battery weight, min./max.	kg	280—400		Fork wheels, bogie, Vulkollan	Ø85x75
Speed control, number of steps		transistor, stepless		Drive wheel, Vulkollan	Ø250x95
Steering arc	°	195			

1) l = 1150

Performance may vary due to motor and system efficiency tolerance and represents nominal values obtained under typical operating conditions.
BT Products AB products and specifications are subject to change without notice.

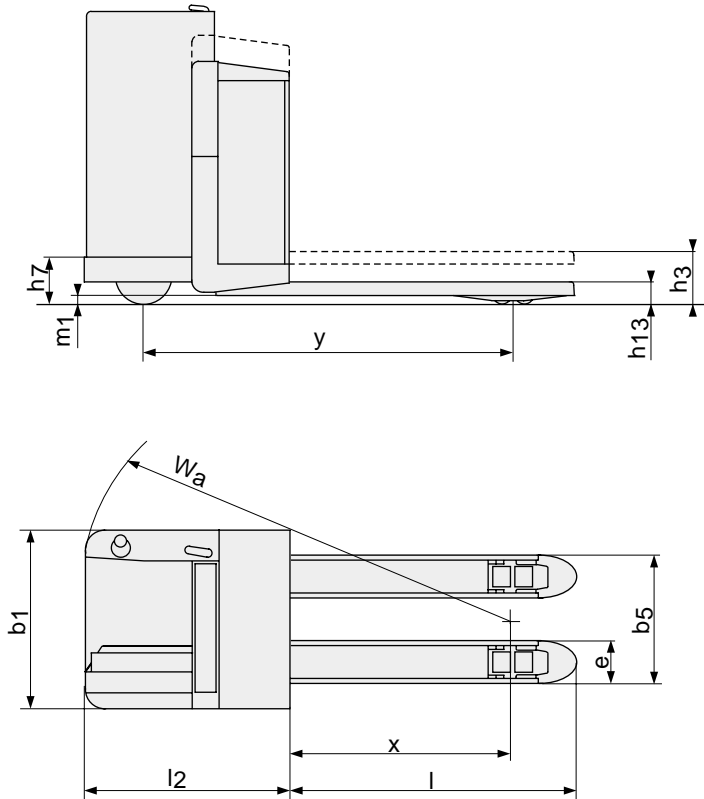

The product complies with the EC-directives



BT Industries

Developed and produced by
BT Products AB



SS-EN ISO 9001, No. 003
ISO 14001, No. M005