



The Pro Lifter M LHT100 from BT is a unique combination of the market leading Hand Pallet truck Lifter LHM230, with the added feature of a motorised drive function. You will get the same high quality level that you recognise from the LHM230. It is easy to manouver and has the compact size of a hand pallet truck which makes it well suited for small spaces.



Technical Details		LHT100
Power unit		Battery
Rated capacity	kg	1000
Weight without battery	kg	89
Drive wheel	mm	Ø 175x50
Fork wheels, single/bogie	mm	Ø 85x100 / Ø 85x75
Pump force, rated capacity	kg	19
Travel speed, without/with rated load	km/h	5,0/3,5
Drive motor	kW	0,2

Dimensions, mm		LHT100
x	Front axle to fork face	985
y	Wheel base	1230
h ₃	Lift height	200
h ₁₄	Height of handle in neutral pos.	1220
h ₁₃	Height of lowered fork	85
l ₂	Truck length incl. back of fork	410
b ₁	Chassis, width	520 / 685
s	Fork thickness	45
e	Fork width	156
l	Fork length	800 / 910 / 1000 / 1070 / 1150 / 1220
b ₅	Width across fork	520 / 685
m ₂	Floor clearance mid wheelbase	40
A _{st}	Aisle width, min (Pallet 800x1200 mm)	1810
W _a	Turning radius	1395

Datas are based on l = 1150mm, nylon wheels

Battery and charger		LHT100
Battery capacity	Ah	24
Battery	V	2 x 12
Battery weight	kg	2 x 9,15
Battery charger	A	3

Pro Lifter M

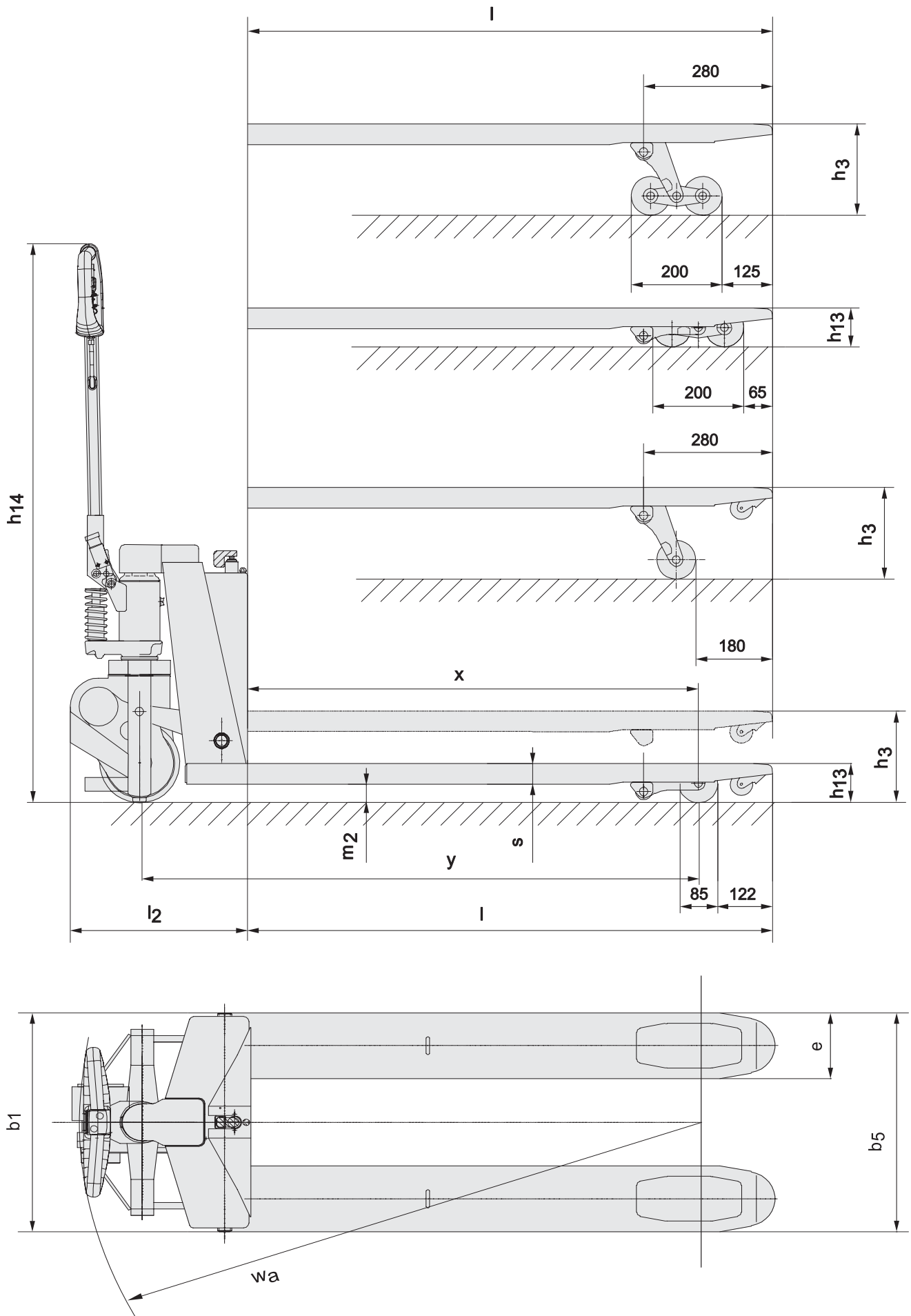

Truck performance and dimensions are nominal and subject to tolerances. BT Products AB products and specifications are subject to change without notice. All data is based on VDI 2198.

Pro Lifter M



- The Pro Lifter M LHT100 will eliminate the strain from pulling and pushing a Hand Truck . This 1000 kg capacity machine is another step towards an ergonomic workplace.
- The safety features include emergency stop key, safety switch against collision, and tow bar switch for the two extreme positions of the tow bar.
- Suitable for indoor applications such as stores, back of store, supermarkets, light industry, hospitals, pharmacies, libraries etc
- Increased ergonomomy, no strain on arms, shoulder and back
- Increases productivity
- Easily operated
- Two direction buttons
- Two speeds. Double-click for higher speed.
- Built-in charger with a separate charging cable.
- Also available in U-model with minimum height 75 mm.
- This product has been environmentally declared. Separate information sheet is available.

Truck features	LHT100
Choice of chassis widths	S
Choice of wheel types	O
Climber wheels	S
Bogie fork wheels	O
Controls and instruments	
Fingertip controls	S
Tiller arm steering	S
Driving features	
180° steering	S
Electronic braking system	S
Electronic speed control	S
Safety features	
Automatic parking brake	S
Emergency cut-off	S
Maintenance features	
Lubrication points	S
Battery management features	
Battery status indicator	S
Built-in charger	S

S = Standard feature

O = Optional feature

— = Not available