



These Ixion-trucks are equipped with wide support arms that straddle the load, allowing operation with a variety of different pallet sizes. They are designed for both horizontal and vertical transports.



Technical Details		SWE120S <sup>1)</sup>	SPE135S <sup>2)</sup>
Operating type		pedestrian	pedestrian/stand on
Rated capacity	kg	1200	1350
Load centre	mm	600	600
Max. axle load drive wheel, without/with rated load	kg	690/735	390/530 <sup>3)</sup>
Max. axle load castor wheel, without/with rated load	kg	—	335/20
Max. axle load support arm wheels, without/with rated load	kg	355/1510	250/870
Travel speed, without/with rated load	km/h	6.0/5.3	8.0/6.8 <sup>4)</sup>
Lift speed, without/with rated load	m/s	0.19/0.10	0.29/0.19
Lowering speed, without/with rated load	m/s	0.15/0.19	0.40/0.55
Gradient, without/with rated load	%	10/8 <sup>5)</sup>	12/10 <sup>5)</sup>
Service-/parking brake		electromagnetic	electromagnetic
Drive motor/Intermittent rating (S2 60')	kW	1.2/60	1.4/60
Lift motor/Intermittent rating (S3 15%)	kW	2.2/5.0	3.1/20
Steering system		steering arm	steering arm
Speed control		transistor, stepless	transistor, stepless
Steering arc	°	208	180

Dimensions, mm		SWE120S	SPE135S
x	Back of fork to wheel centre, bogie/single	—/697	697/667 <sup>6)</sup>
y	Wheel base	1332	1330 <sup>7)</sup> / 1360 <sup>8)</sup>
	Drive wheel movement up/down	—	15/30
	Drive wheel, Powerfriction <sup>9)</sup>	Ø 215	Ø 215x70
	Castor wheels, Vulkollan	—	Ø 125x50
	Support arm wheels, bogie/single, Vulkollan	Ø 100x75	Ø 85x75 / Ø 140x60
h <sub>7</sub>	Platform height	170	150
l <sub>4</sub>	Platform length	400	400
h <sub>14</sub>	Height of handle in neutral pos.	1365	1435 <sup>10)</sup>
h <sub>8</sub>	Height of support arm	100 <sup>7)</sup>	140 <sup>7)</sup> / 85 <sup>8)</sup>
h <sub>13</sub>	Height of lowered fork	50	60
l <sub>2</sub>	Truck length incl. fork face, without/with platform up/down	805/897/1271	890/920/1347 <sup>11)</sup>
b <sub>1</sub>	Chassis, width	800	850
b <sub>2</sub>	Width across support arms, bogie/single	—/1100—1500	1160—1560/1070—1470
s	Fork thickness	40	40
e	Fork width	100	100
l	Fork length	1000/1150	600/800/900/1000/1150/1400
b <sub>5</sub>	Width across fork, min.—max.	252—800	260—900
b <sub>4</sub>	Width between support arms, min.—max.	900—1300	900—1300
b <sub>14</sub>	Width of support arm, bogie/single	—/100	130/85
m <sub>1</sub>	Floor clearance, bogie/single	—/40	25/40
A <sub>st</sub>	Aisle width, without/platform up/down	2222/2323/2968	2449/2479/2881
W <sub>a</sub>	Turning radius, without/with platform up/down, bogie	—	1603/1633/2060
W <sub>a</sub>	Turning radius, without/with platform up/down, single	1519/1620/1995	1575/1603/2030

Mast SWE120S			Simplex			Duplex Tele			Duplex Hi-Lo				
<b>h<sub>23</sub></b>	<b>Total lift height</b>	<b>mm</b>	<b>1350</b>	<b>1650</b>	<b>2650</b>	<b>2850</b>	<b>3250</b>	<b>3650</b>	<b>2650</b>	<b>2850</b>	<b>3250</b>	<b>3650</b>	<b>4100</b>
h <sub>1</sub>	Height of mast, min.	mm	1790	2095	1809	1915	2114	2314	1809	1915	2114	2314	2539
h <sub>2</sub>	Free lift	mm	1350	1650	150	150	150	150	1350	1450	1650	1850	2075
h <sub>4</sub>	Height of mast, max.	mm	1790	2095	3080	3290	3690	4090	3080	3290	3690	4090	4540
	Weight without battery <sup>12)</sup>	kg	650	664	721	730	748	766	721	730	748	766	805
	Battery (5h discharge), min./max.	V/Ah	24/165/300										
	Battery weight, min./max.	kg	150/260										

Mast SPE135S			Duplex Tele			Duplex Hi-Lo					Triplex Hi-Lo					
<b>h<sub>23</sub></b>	<b>Total lift height</b>	<b>mm</b>	<b>2350</b>	<b>2800</b>	<b>3350</b>	<b>2350</b>	<b>2900</b>	<b>3350</b>	<b>3750</b>	<b>4150</b>	<b>3350</b>	<b>3750</b>	<b>4150</b>	<b>4500</b>	<b>4800</b>	<b>5400</b>
h <sub>1</sub>	Height of mast, min.	mm	1710	1935	2210	1710	1985	2210	2420	2620	1680	1815	1950	2065	2165	2365
h <sub>2</sub>	Free lift	mm	—	—	—	1195	1470	1695	1895	2095	1160	1295	1430	1545	1645	1845
h <sub>4</sub>	Height of mast, max.	mm	2870	3320	3870	2870	3420	3870	4280	4680	3875	4275	4675	5025	5325	5925
	Weight without battery <sup>12)</sup>	kg	1040	1060	1090	1060	1090	1120	1140	1160	1140	1160	1180	1200	1220	1250
	Battery (5h discharge), min./max.	V/Ah	24/180/440													
	Battery weight, min./max.	kg	200—250/300—370													

Truck performance and dimensions are nominal and subject to tolerances.  
BT Products AB products and specifications are subject to change without notice.  
All data is based on VDI 2198.

## SWE120S

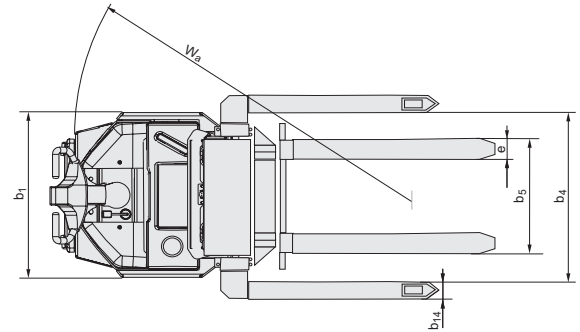
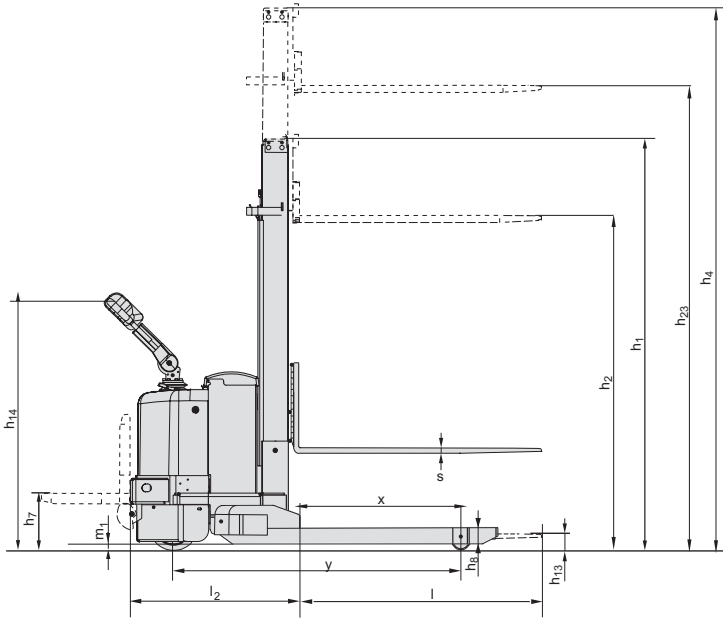

## SPE135S

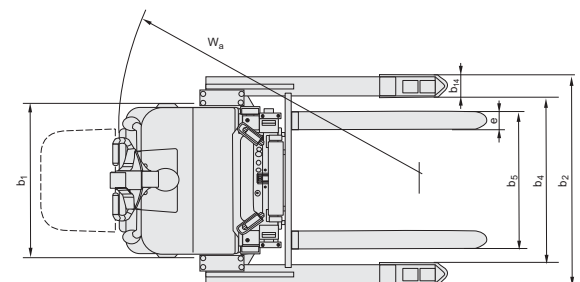
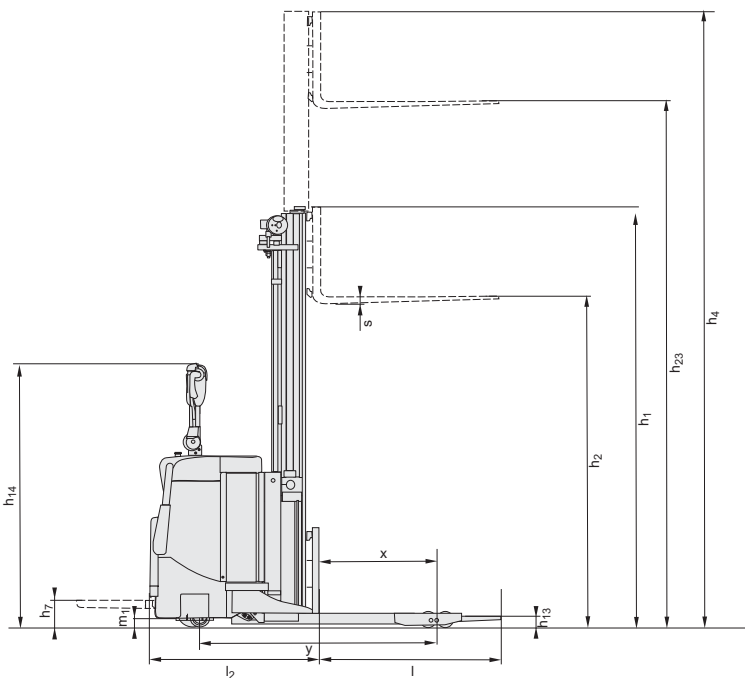

- 1) Data is based on medium battery compartment,  $l = 1150$  mm,  $h_{23} = 3250$  mm, without platform
- 2) Data is based on small size battery compartment and Triplex mast. Large battery compartment = +98 mm and +30 kg
- 3) Increased axle load = +80 kg
- 4) Version without platform = 6/6
- 5) Due to motor characteristics, please ask technical support regarding driving on ramps and gradients.
- 6) Triplex mast -20 mm

- 7) Support arm wheels = single
- 8) Support arm wheels = bogie
- 9) Other alternatives available
- 10) Height of handle in neutral position without platform = 1580 mm, in normal driving position = 1040 mm.
- 11) Triplex mast +20 mm
- 12) Platform weight = 30 kg



- The comfortable steering arm, with its modern design, facilitates one hand operation. The lift, lowering and driving functions are ergonomically placed on the steering arm and can be operated by finger tip force.
- Individual driver parameters, top speed, acceleration and automatic speed reduction, to meet driver skills can be programmed via the key board (no tool needed).
- The BT Powerdrive system provides reliability and simplicity. Can-bus technology means fewer parts and reliable transmission of data. A Pin code start up procedure offers higher operational safety by stopping unauthorised driving.
- Two different battery compartments provide the truck with excellent flexibility.
- The SPE-truck is equipped with Powertrak drive unit configuration — a BT patent. The drive wheel pressure is constantly adjusted due to the weight of the load. The result is excellent stability, optimal traction and steering force.
- The Sensi-lift function on the SPE135S offer precise and intuitive control of the lift and lowering speeds.

Truck features	SWE120S	SPE135S
Adjustable fork width	S	S
BT Powerdrive System	S	S
Powertrak traction system	—	S
Controls and instrument		
Fingertip controls	S	S
Information display	S	S
Power/Electronic steering	—	O
Temporary speed reduction (turtle button)	O	O
Tiller arm steering	S	S
Driving features		
180° steering	—	S
208° steering	S	—
Electronic braking system	S	S
Electronic speed control	S	S
Flip-down driver platform	O	S
Safety features		
BT Access Control	S	S
Clear-view mast	S	S
Folding sideguards	—	S
Programmable performance	S	S
Maintenance features		
Easy access for maintenance	S	S
Fault diagnosis facility	S	S
Battery management features		
Battery status indicator	S	S
Heavy duty battery compartments	O	O
Special applications		
Coldstore version	—	O

S = Standard feature

O = Optional feature

— = Not available



The product complies with the EC-directives



SS-EN ISO 9001, No. 003  
ISO 14001, No. M005

BT  
SE-595 81 Mjölby Sweden  
Tel: +46 (0)142 860 00  
Fax: +46 (0) 142 866 00  
Email: info@bt-forklifts.com  
www.bt-forklifts.com

