



Specially designed for corrosive environments or applications that demand high standards of hygiene — such as food processing or pharmaceutical industries.



Technical Details		LHM200ST
Rated capacity	kg	2000
Weight	kg	70
Steering wheels	mm	Ø 175x60
Fork wheels, single/bogie	mm	Ø 85x100/Ø 85x75

Dimensions, mm		LHM200ST
x	Front axle to fork face	985
y	Wheel base	1217
h ₃	Lift height	200
h ₁₄	Height of handle in neutral pos.	1220
h ₁₃	Height of lowered fork	85
l ₂	Truck length incl. back of fork	356
b ₁	Chassis, width	520/695
s	Fork thickness	45
e	Fork width	156
l	Fork length	800/910/1000/1150/1220
b ₅	Width across fork	520/685
m ₂	Floor clearance mid wheelbase	40
A _{st}	Aisle width, min Pallet 800x1200 mm	1756
W _a	Turning radius	1392

Datas are based on l = 1150mm, nylon wheels

Stainless Lifter

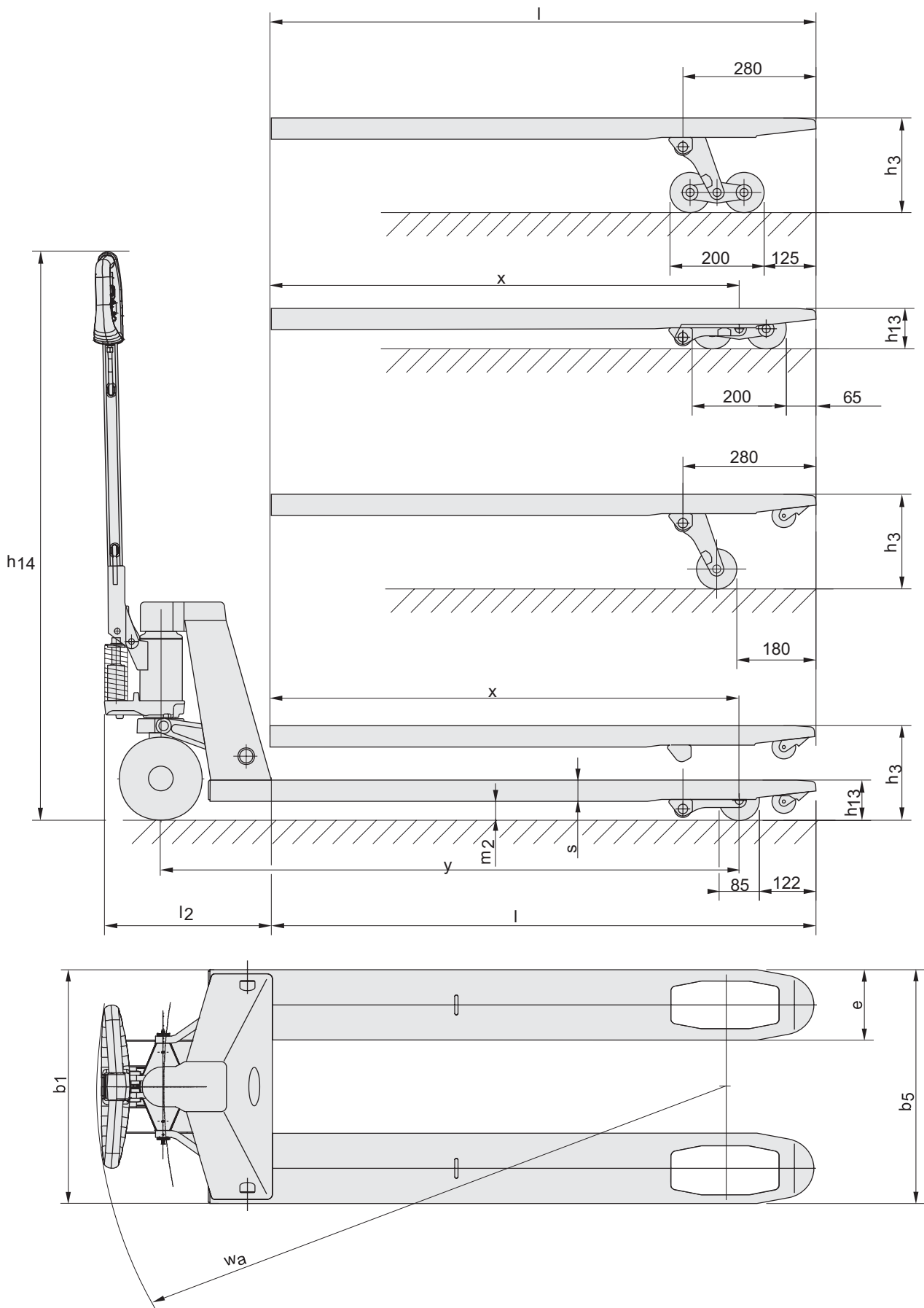

Truck performance and dimensions are nominal and subject to tolerances.
BT Products AB products and specifications are subject to change without notice.
All data is based on VDI 2198



- All components in stainless steel or other non-corroding materials gives the truck reliability and long life.
- All surfaces are glass blasted to give a smooth surface and ensure easy cleaning.
- Welded tow bar attachment provides high reliability.
- 10/12 greasable bushings ensure a long service life.
- Also available in U-model with minimum height 75 mm.
- This product has been environmentally declared. Separate information sheet is available.

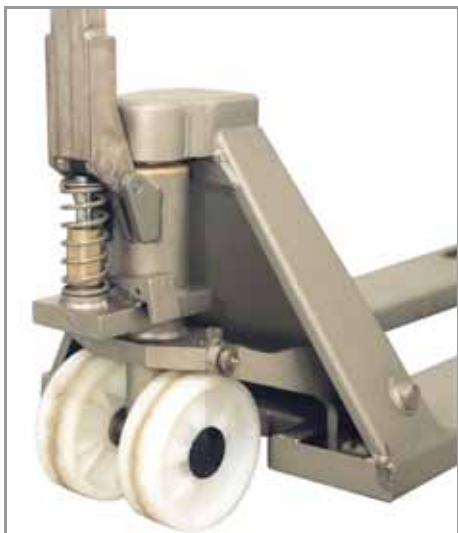

Truck features	LHM200ST
Choice of chassis widths	S
Choice of other fork lengths	S
Choice of wheel types	O
Climber wheels	S
Quick-lift version	—
Bogie fork wheels	O
Controls and instruments	
Tiller arm steering	S
Driving features	
180° steering	S
Safety features	
Handbrake	—
Parking brake	—
Maintenance features	
Lubrication points	S
Special applications	
Coldstore version	S

S = Standard feature

O = Optional feature

— = Not available

ITS, Sweden — 745100-040, 0605