



To get a hand pallet truck moving is the heaviest part of the transport. With BT Pro Lifter the truck will take the first steps by itself. A hand pallet truck loaded with 2300 kg needs a starting force of 45 kg to get into motion. With BT Pro Lifter you only need 15 kg.



Technical Details		LHM230P
Rated capacity	kg	2300
Weight	kg	75
Steer wheel	mm	Ø 175x60
Fork wheels, single/bogie	mm	Ø 85x100/ Ø 85x75
Pump force, rated capacity	kg	34
Pulling force		22 <sup>1)</sup>

Dimensions, mm		LHM230P
x	Front axle to fork face	985
y	Wheel base	1210
h <sub>3</sub>	Lift height	200
h <sub>14</sub>	Height of handle in neutral pos.	1220
h <sub>13</sub>	Height of lowered fork	85
l <sub>2</sub>	Truck length incl. back of fork	425
b <sub>1</sub>	Chassis, width	520/685 <sup>2)</sup>
s	Fork thickness	45
e	Fork width	156
l	Fork length	800/910/1000/1070/ 1150/1220 <sup>2)</sup>
b <sub>5</sub>	Width across fork	520/685 <sup>2)</sup>
m <sub>2</sub>	Floor clearance mid wheelbase	40
A <sub>st</sub>	Aisle width, min (Pallet 800x1200 mm)	1825
W <sub>a</sub>	Turning radius	1410

- 1) With rated capacity on a smooth, dry level concrete floor  
2) Other fork lengths and widths on request

Datas are based on l = 1150mm, powerthane wheels

## BT Pro Lifter

with 2300 kg load

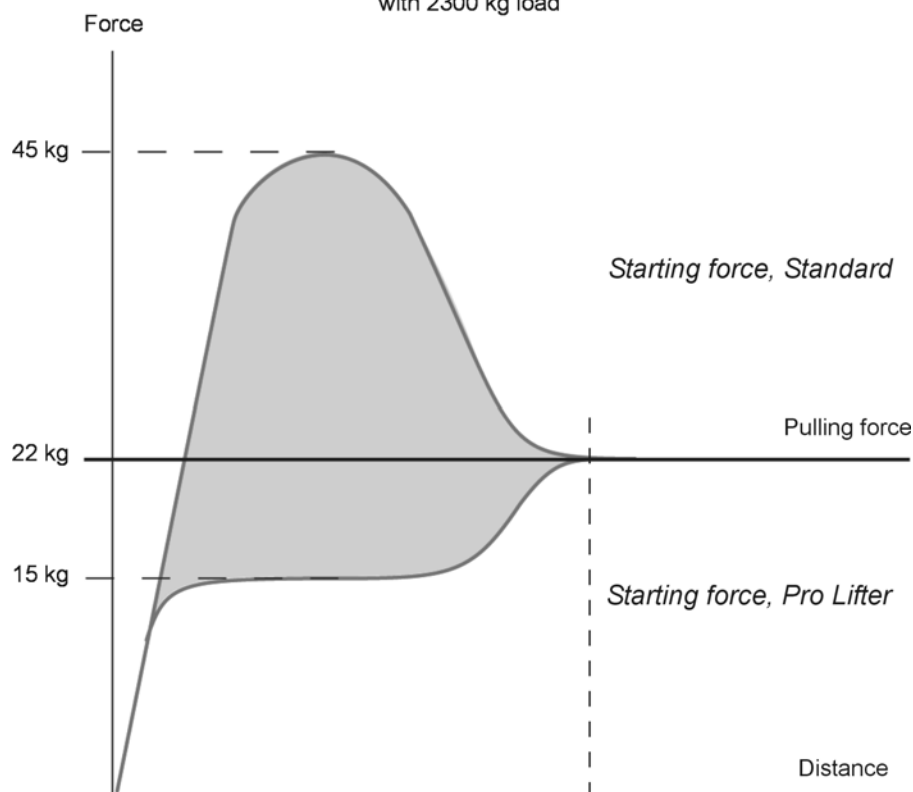

One third of the wheels periphery

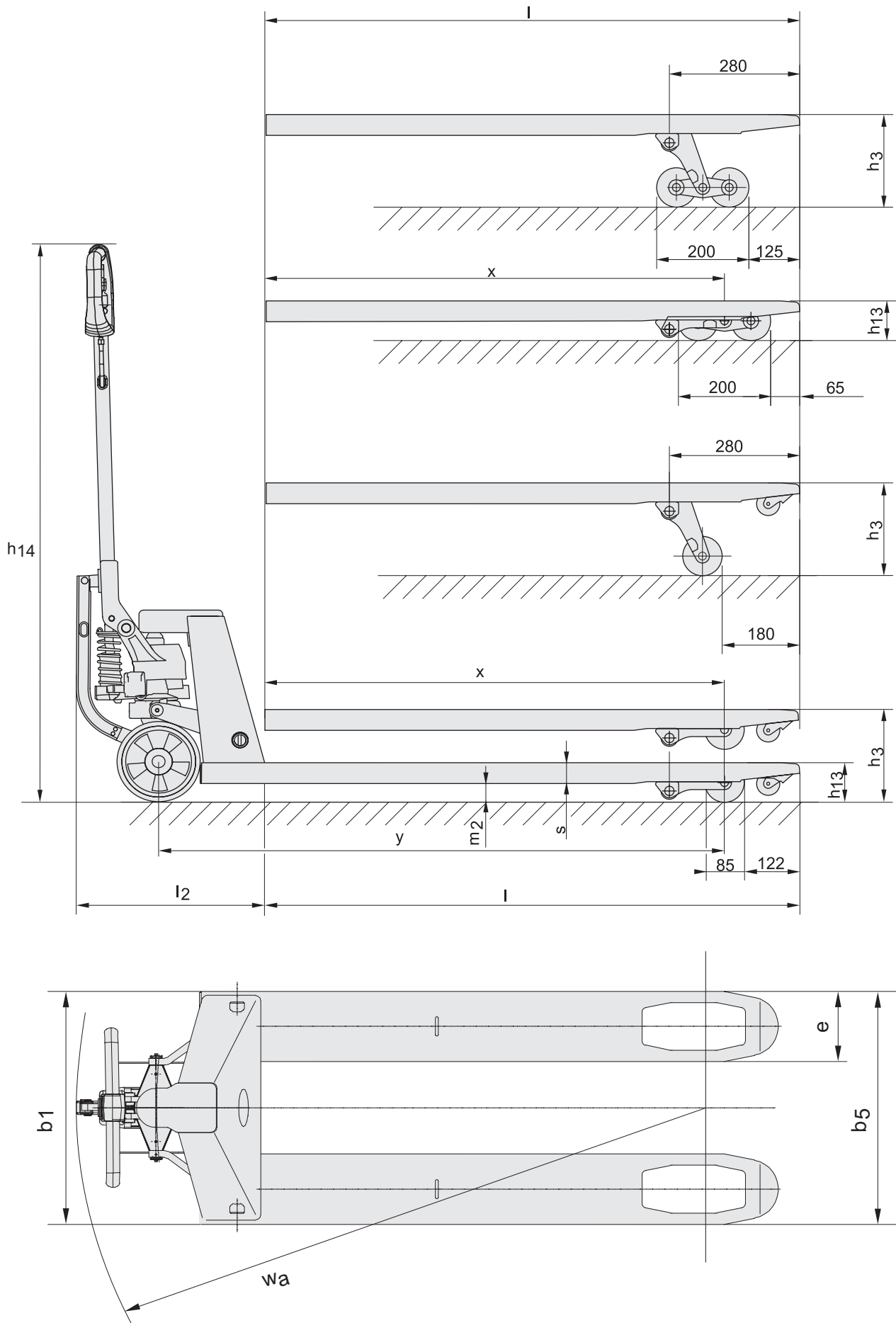



- A connection between the tow bar and the steering wheels transfer the force from the pump stroke to the wheel to get the truck started.
- Through a control on the handle you can choose the direction of the starting force.
- Unique option for heavy duty applications and easy positioning.
- Smooth driving over uneven surfaces and thresholds.
- High ergonomics, reduces strain to arms, shoulders and back.
- Increases the productivity.
- Steer wheel in powerthane or powerfriction.
- The Quick Lift is the best ergonomic choice, because the number of pump strokes are reduced.
- With over load you protect the truck and floors from being over loaded.
- This unique Pro Lifter pump can be assembled on any length or width on a LHM230 including reel drum handling.
- BT's unique lifetime guarantee, gives the customer 99-years factory guarantee on the fork frame, valid for defects in materials and welding faults which can be derived from manufacturing. The guarantee on the pump unit and the tow bar is five years and on the Pro Lifter function 3 years.
- This product has been environmentally declared. Separate information sheet is available.

Truck features	LHM230P
Choice of chassis widths	S
Choice of fork lengths	S
Choice of wheel types	S
Climber wheels	S
Bogie fork wheels	S
Controls and instruments	
Tiller arm steering	S
Driving features	
180° steering	S
Safety features	
Handbrake	—
Parking brake	—
Load support	O
Maintenance features	
Lubrication points	S

S = Standard feature

O = Optional feature

— = Not available

BT  
 SE-595 81 Mjölby Sweden  
 Tel: +46 (0)142 860 00  
 Fax: +46 (0) 142 866 00  
 Email: info@bt-forklifts.com  
 www.bt-forklifts.com

