

1200SE
1200HSE
SPACE



The OPW truck is optimized for handling large articles, on standard or special load carriers. Large, bulky articles are best handled using the OPW SPACE.



Technical Details	OPW 1200SE	OPW 1200HSE	OPW SPACE
Power unit	electrical, battery		
Operating type	stand on		
Rated capacity	kg 1200	1200	1200
Load centre	mm 600	600	1000
Weight without battery	kg 2391 ¹⁾	2760 ²⁾	2935 ³⁾
Wheel type	polyurethane		
Wheel dimension, fork side	mm Ø 230x110	Ø 230x110	Ø 230x110
Wheel dimension, drive wheel side	mm Ø 310x110	Ø 310x110	Ø 310x110
Number of wheels, fork side	2	2	4
Number of wheels, drive wheel side	1	1	1
Travel speed, without/with rated load	km/h 9/8	9/8	9/8
Lift speed, without/with rated load	m/s 0.33/0.24	0.33/0.24	0.33/0.24
Lift speed, with 500 kg	m/s 0.28	0.28	0.28
Lowering speed, without/with rated load	m/s 0.38/0.38	0.38/0.38	0.38/0.38
Lowering speed, with 500 kg	m/s 0.38	0.38	0.38
Service brake, hand operated	3 stage electromagnetic spring pressure		
Parking brake, (dead man's grip)	3 stage electromagnetic spring pressure		
Drive motor/Intermittent rating	kW/% 5.0/60	5.0/60	5.0/60
Lift motor/Intermittent rating	kW/% 7.6/20	7.6/20	7.6/20
Battery weight	kg 550—750	550—750	550—750
Battery (5h discharge) — approx.	V/Ah 48/315—520	48/315—520	48/315—520
Steering system	electronic power steering		
Speed control, number of steps	transistor, stepless		

Dimensions, mm	OPW 1200SE	OPW 1200HSE	OPW SPACE
x Front axle to fork back	270	270	290
y Wheel base	1444	1444	1644
b ₁₀ Track width fork side c/c	879	1109	1245
z ₁₁ Width between rails, min	200/230 + b ₁ ⁴⁾	200/230 + b ₁ ⁴⁾	200/230 + b ₁ ⁴⁾
h ₆ Height of cab	2435	2435	2435
h ₂₁ Height of cab inside	2050	2050	2050
h ₂₂ Height of cab sides	900	900	900
h ₇ Instep height	315	315	315
h ₁₃ Height of lowered fork	80	80	80
l ₂₁ Load frame length std, inside	820/1020/1220 ⁵⁾	820/1020/1220 ⁵⁾	—
b ₂₁ Load frame width std, inside	890/1090/1290 ⁶⁾	890/1090/1290 ⁶⁾	⁷⁾
l ₂ Truck length incl. back of fork	1912	1912	2132
l ₂₀ Cab length, floor	680	680	680
l ₂₄ Entrance width	425	425	425
b ₁ Chassis, width	1020	1250	1475
b ₂ Cab width	1000—1800 ⁸⁾ + 1460	1000—1800 ⁸⁾ +1460	1800—2500 ⁸⁾
s Fork thickness	62	62	72
e Fork width	115	115	120
l Fork length	850/1050/1250	850/1050/1250	850—1650 ⁸⁾ , 1200
b ₅ Width across fork	560/685/776	560/685/776	
m ₂ Floor clearance mid wheelbase	60 ⁹⁾	60 ⁹⁾	60 ⁹⁾
W _a Turning radius	1664	1664	1864

- 1) h₁₂ = 4500 mm, b₁ = 1020 mm, walk through
- 2) h₁₂ = 7500 mm, b₁ = 1250 mm, walk through
- 3) h₁₂ = 7500 mm, b₁ = 1475 mm, walk through
- 4) Depending on type of rails
(low profile rails: +200mm, high profile: +230mm)
- 5) Outside: +80 mm
- 6) Outside: +120 mm
- 7) To be produced locally
- 8) in 100 mm steps
- 9) 25 mm if wire guided

Truck performance and dimensions are nominal and subject to tolerances.
BT Products AB products and specifications are subject to change without notice.
All data is based on VDI 2198.

Dimensions, mm													
Duplex Mast													
h_{12}	Platform height	3550	3950	4000	4500	5000	5500	6000	6500	7000	7500	8000	8500
OPW 1200SE													
h_1	Height of truck, min.	2450	2650		2925	3175							
h_3	Lift movement	3235	3635		4185	4685							
h_4	Height of truck, max.	5705	6105		6655	7155							
h_{20}	Picking height	5150	5550		6100	6600							
h_{23}	Total lift height ¹⁾	3315	3715		4265	4765							
OPW 1200HSE													
h_1	Height of truck, min.						3425	3675	3925	4175	4425	4675	4925
h_3	Lift movement						5185	5685	6185	6685	7185	7685	8185
h_4	Height of truck, max.						7655	8155	8655	9155	9655	10155	10655
h_{20}	Picking height						7100	7600	8100	8600	9100	9600	10100
h_{23}	Total lift height ¹⁾						5265	5765	6265	6765	7265	7765	8265
OPW SPACE													
h_1	Height of truck, min.			2925	3175	3425	3675	3925	4175	4425	4675	4925	
h_3	Lift movement			3685	4185	4685	5185	5685	6185	6685	7185	7685	
h_4	Height of truck, max.			6155	6655	7155	7655	8155	8655	9155	9655	10155	
h_{20}	Picking height			5600	6100	6600	7100	7600	8100	8600	9100	9600	
h_{23}	Total lift height ¹⁾			3765	4265	4765	5265	5765	6265	6765	7265	7765	

Dimensions, mm													
Triplex Mast													
h_{12}	Platform height	4700	5500	6100	7300	8200	9500						
OPW 1200HSE													
h_1	Height of truck, min.	2435	2680	2880	3390	3890	4325						
h_3	Lift movement	4385	5185	5785	6985	7885	9185						
h_4	Height of truck, max.	6855	7655	8255	9455	10355	11655						
h_{20}	Picking height	6300	7100	7700	8900	9800	11100						
h_{23}	Total lift height ¹⁾	4465	5265	5865	7065	7965	9265						

1) $h_{23} = h_{13} + h_3$

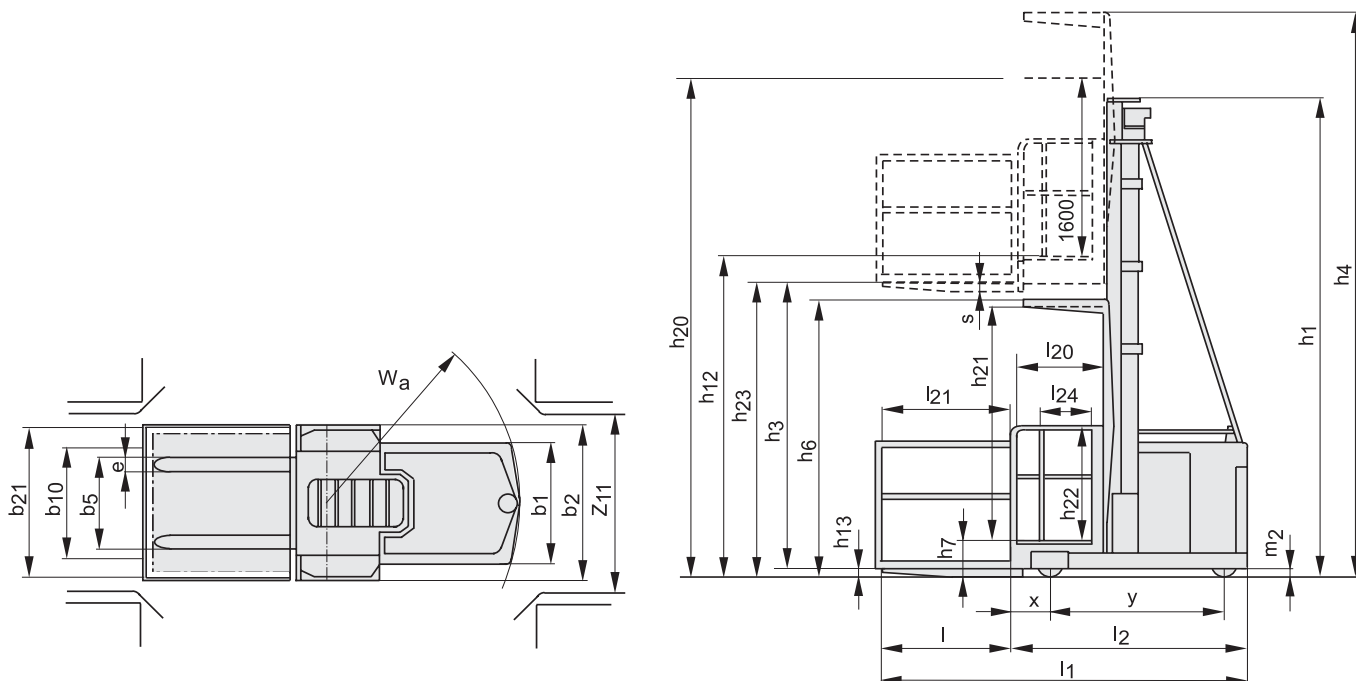



- The Triplex mast offers a picking height up to 11.1m combined with a minimized collapsed height.
- Optipace allows the best acceleration rate and travel speed at all heights.
- Stable gates together with a flat floor allows comfortable and safe picking.
- A good working environment for the driver is created by adjustable control panel and backrest.
- A flexible and adjustable cab design will cater for individual needs. As an example, it is possible to transform a walk through unit into a OP with auxiliary lift machine in less than three hours.
- A complete auto test routine is done every time the machine is turned on. This self-test is continuously repeated during operation.
- Parameters like acceleration, deceleration and top speed can easily be reprogrammed if necessary.
- Easy access to all the vital components (motor, pump etc.) simplifies service and maintenance

Truck features	OPW 1200SE	OPW 1200HSE	OPW SPACE
Elevating platform	S	S	S
Choice of chassis widths	S	S	S
Choice of cab widths	S	S	S
Controls and instruments			
Power/Electronic steering	S	S	S
Mini-joystick electronic controls	S	S	S
Driving features			
Electronic braking system	S	S	S
Electronic speed control	S	S	S
Safety features			
Automatic parking brake	S	S	S
BT Optipace system	S	S	S
Driver detection system	S	S	S
Folding sideguards	S	S	S
Clear-view mast	S	S	S
Emergency cut-off	S	S	S
Warning beacon	S	S	S
Drivers compartment features			
Storage compartments	S	S	S
Maintenance features			
Fault diagnosis facility	S	S	S
History fault log	S	S	S
Battery management features			
Battery status indicator	S	S	S
Side-ways battery change	S	S	S
Special applications			
Coldstore version	O	O	O
Wire/rail guidance	O	O	O

S = Standard feature

O = Optional feature

— = Not available



The product complies with the EC-directives



SS-EN ISO 9001, No. 003
ISO 14001, No. M005

BT
SE-595 81 Mjölby Sweden
Tel: +46 (0)142 860 00
Fax: +46 (0) 142 866 00
Email: info@bt-forklifts.com
www.bt-forklifts.com

