



The OSE100 is designed to work effectively in first and second level picking applications. The comfort level of this truck is very high since both the platform and load carrier always are close to the operator. Good performance together with an ergonomic, reliable design will help users to achieve a high level of productivity.



Technical Details	OSE100
Power unit	Electr. battery
Operating type	Stand on
Rated capacity	kg 1000
Load centre	mm 600
Weight without battery	kg 1294
Max axle load drive wheel, without/with rated load	kg 1113/550
Max axle load supp.wheel, without/with rated load	kg 365/1149
Support arm wheels, Vulkollan	mm Ø140x70
Drive wheel, Vulkollan	mm Ø250x105
Travel speed, without/with rated load	km/h 12.0/7.0
Travel speed, without/with rated load, in fork direction	km/h 10.5/6.0
Lift speed, without/with rated load	m/s 0.16/0.12
Lowering speed, without/with rated load	m/s 0.17/0.18
Gradient, without/with rated load	% 13/6
Service-/parking brake	1 stage electromagnetic brake
Drive motor/Intermittent rating	kW/% 2.5/60
Lift motor/Intermittent rating	kW/% 2.2/5.0
Battery (5h discharge)	V/Ah 24/465—620
Battery weight, min./max.	kg 475/530 ¹⁾
Steering system	electronic
Speed control	stepless
Steering arc	° 200

Dimensions, mm	OSE100
x Back of fork to wheel centre	158
y Wheel base	1351
h ₇ Instep height	180
h ₉ Auxiliary lift movement	780
h ₁₃ Height of lowered fork	80
h ₁ Height of mast, min.	1550
h ₃ Lft movement	1020
h ₄ Height of mast, max.	2570
h ₁₂ Platform height	1200
h ₂₃ Total lift height	1880
l ₂ Truck length incl. back of fork	1690
b ₁ Chassis, width	790
s Fork thickness	62
e Fork width	115
l Fork length	800/1000/1150
b ₅ Width across fork, min.—max.	300—750
m ₂ Floor clearance mid wheelbase	70
W _a Turning radius	1540
l ₉ Platform length	548
l ₂₄ Entrance width	471

1) If less than 475kg, add counterweight up to minimum weight.

Truck performance and dimensions are nominal and subject to tolerances.
BT Products AB products and specifications are subject to change without notice.
All data is based on VDI 2198.

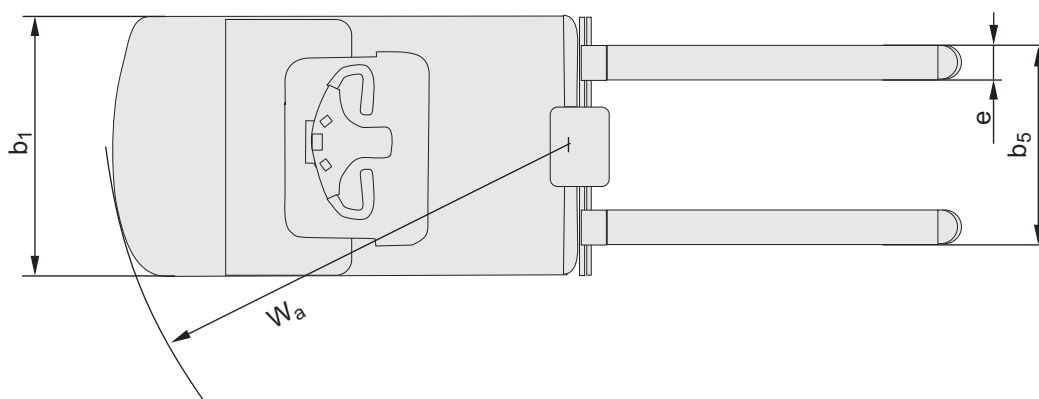
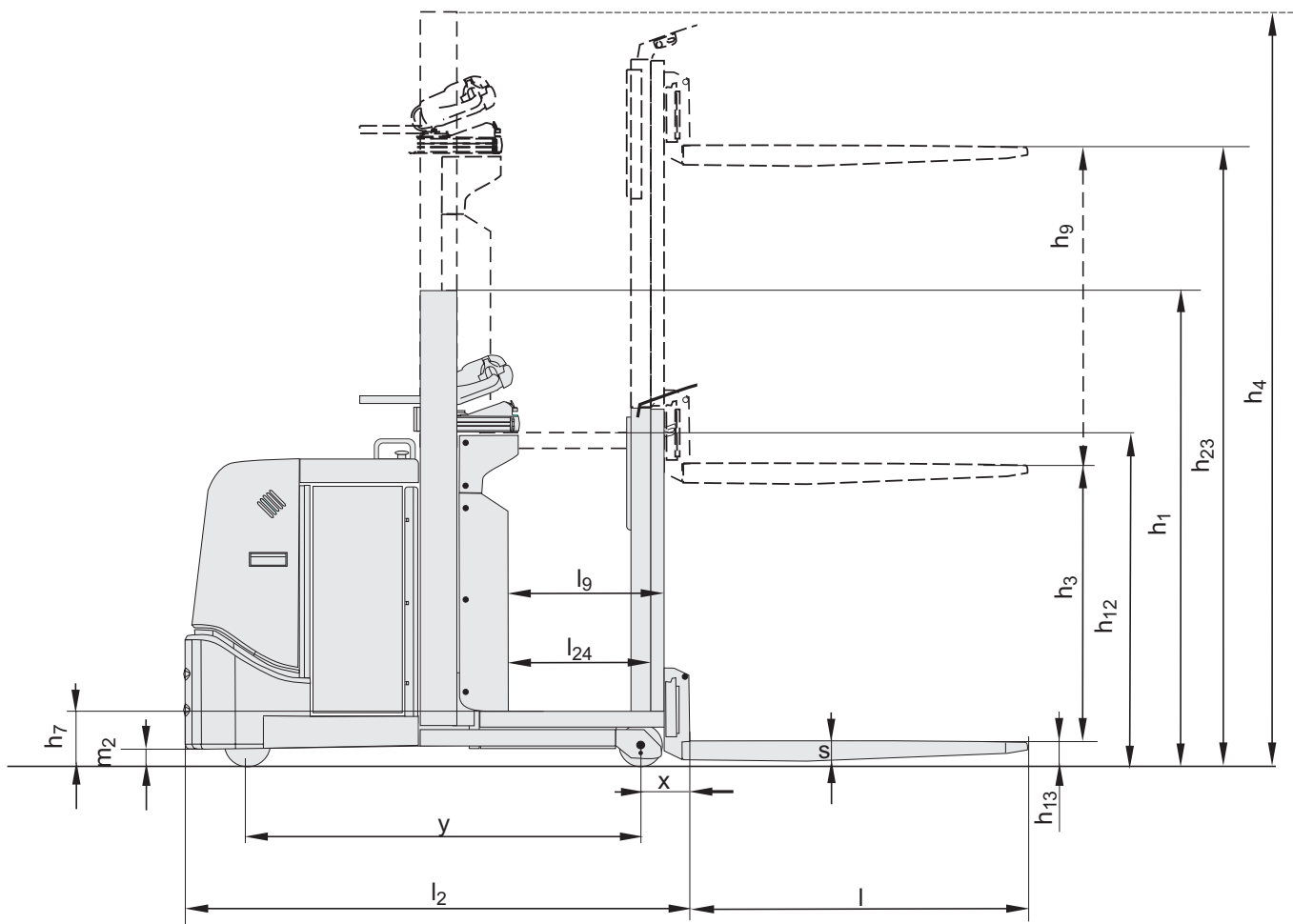



- The new E-MAN steering concept is ideally suitable for picking activities. Light, one hand operation increases the flexibility for the driver and at the same time simplifies driving in the fork direction.
- The BT POWERDRIVE system provides reliability and simplicity. CAN-bus technology means fewer parts and reliable transmission of data. A PIN code start up procedure offers higher operational safety by stopping unauthorised driving.
- With the initial lift in front, the driver can easily adjust the pallet to suit individual needs. The lift capacity is 1000kg.
- The performance of the OSE100 is first-rate. A travel speed of 12 km/h together with high acceleration increases the number of pick-ups. With our motor technology it is very easy to adjust top speed, acceleration and speed reduction to meet individual requirements. There are 10 individually adjustable operator programs.

Truck features	OSE100
BT Powerdrive System	S
Elevating platform	S
High performance models	S
Controls and instrument	
Fingertip controls	S
Information display	S
Power/Electronic steering	S
Driving features	
200° steering	S
Automatic deceleration	S
Electronic regenerative brakes	S
Safety features	
BT Access Control	S
Driver detection system	S
Programmable performance	S
Drivers compartment features	
Elevating platform	S
Low step-in	S
PC Bracket	O
Storage compartments	S
Writing table	O
Maintenance features	
Easy access for maintenance	S
Fault diagnosis facility	S
Battery management features	
Battery change facility	O
Battery status indicator	S

S = Standard feature

O = Optional feature

— = Not available