



The OSE120CB is perfectly suited for intense picking together with occasional stacking activities. The OSE120CB is designed to simplify the entire order picking process by adding pallet handling as an extra feature. Efficiency together with safety are key words.



Technical Details		OSE120CB
Power unit		Electr. battery
Operating type		Stand on
Rated capacity	kg	1200
Load centre	mm	500
Weight without battery, max.	kg	1549
Max axle load drive wheel, without/with rated load	kg	1100/615
Max axle load supp.wheel, without/with rated load	kg	1038/2725
Drive wheel, Vulkollan	mm	Ø250x105
Support arm wheels, Vulkollan	mm	Ø140x70
Travel speed, without/with rated load	km/h	12.0/7.0
Travel speed, without/with rated load, in fork direction		9.0/6.0
Lift speed, without/with rated load	m/s	0.19/0.10
Lowering speed, without/with rated load	m/s	0.18/0.19
Gradient, without/with rated load	%	13/7
Service-/parking brake		1 stage electromagnetic brake
Drive motor/Intermittent rating	kW/%	2.5/60
Lift motor/Intermittent rating	kW/%	2.2/5.0
Battery (5h discharge)	V/Ah	24/465—620
Battery weight, min./max.	kg	475/530 <sup>1)</sup>
Steering system		electronic
Speed control		stepless
Steering arc	°	200

Dimensions, mm		OSE120CB
x	Back of fork to wheel centre	73
y	Wheel base	1448
h <sub>6</sub>	Height overhead guard	2196 <sup>2)</sup>
h <sub>7</sub>	Instep height	130
h <sub>13</sub>	Height of lowered fork	50
l <sub>2</sub>	Truck length incl. back of fork	1703
b <sub>1</sub>	Chassis, width	790
b <sub>2</sub>	Support wheel brackets	799
s	Fork thickness	40
e	Fork width	100
l	Fork length	1000/1150/1200
b <sub>5</sub>	Width across fork, min./max.	250/570
m <sub>1</sub>	Floor clearance under mast	49
m <sub>2</sub>	Floor clearance mid wheelbase	72
A <sub>st</sub>	Aisle width, min.	3032
W <sub>a</sub>	Turning radius	1636
l <sub>9</sub>	Platform length	450

Mast, mm	Simplex				Duplex Tele				Duplex Hi-Lo					
<b>h<sub>23</sub></b>	<b>Total lift height <sup>2)</sup></b>				<b>2650</b>	<b>2850</b>	<b>3250</b>	<b>3650</b>	<b>2650</b>	<b>2850</b>	<b>3250</b>	<b>3650</b>	<b>4100</b>	
h <sub>1</sub>	Height of mast, min.	1345	1795	2095	2245	1809 <sup>3)</sup>	1915 <sup>3)</sup>	2114 <sup>3)</sup>	2314	1809 <sup>3)</sup>	1915 <sup>3)</sup>	2114 <sup>3)</sup>	2314	2539
h <sub>2</sub>	Free lift	900	1350	1650	1800	150	150	150	150	1350	1450	1650	1850	2075
h <sub>4</sub>	Height of mast, max.	1345	1795	2095	2245	3080	3290	3690	4090	3080	3290	3690	4090	4540

- 1) If less than 475kg, add counterweight up to minimum weight  
2) Over head guard is mandatory for h<sub>23</sub> above 1800mm  
3) Truck height is limited by h<sub>6</sub>

Truck performance and dimensions are nominal and subject to tolerances.  
BT Products AB products and specifications are subject to change without notice.  
All data is based on VDI 2198.

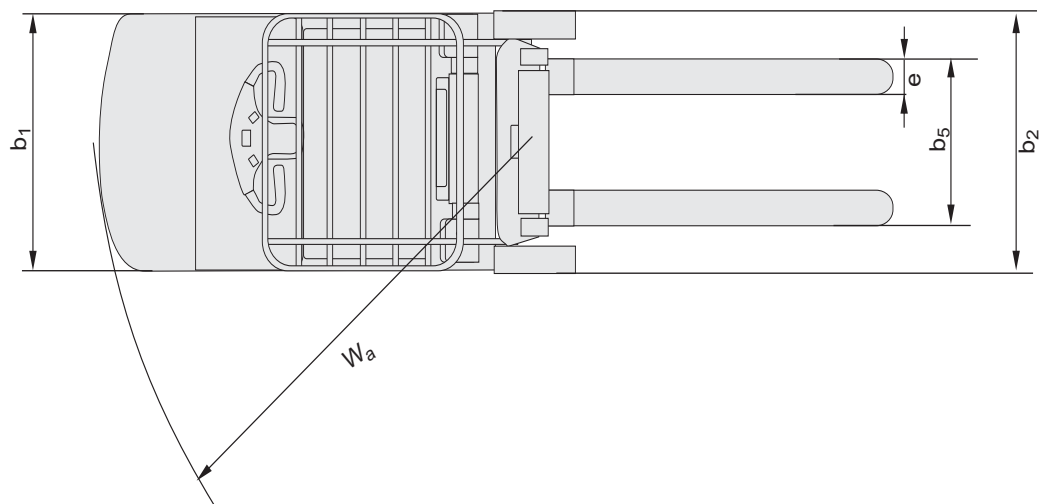
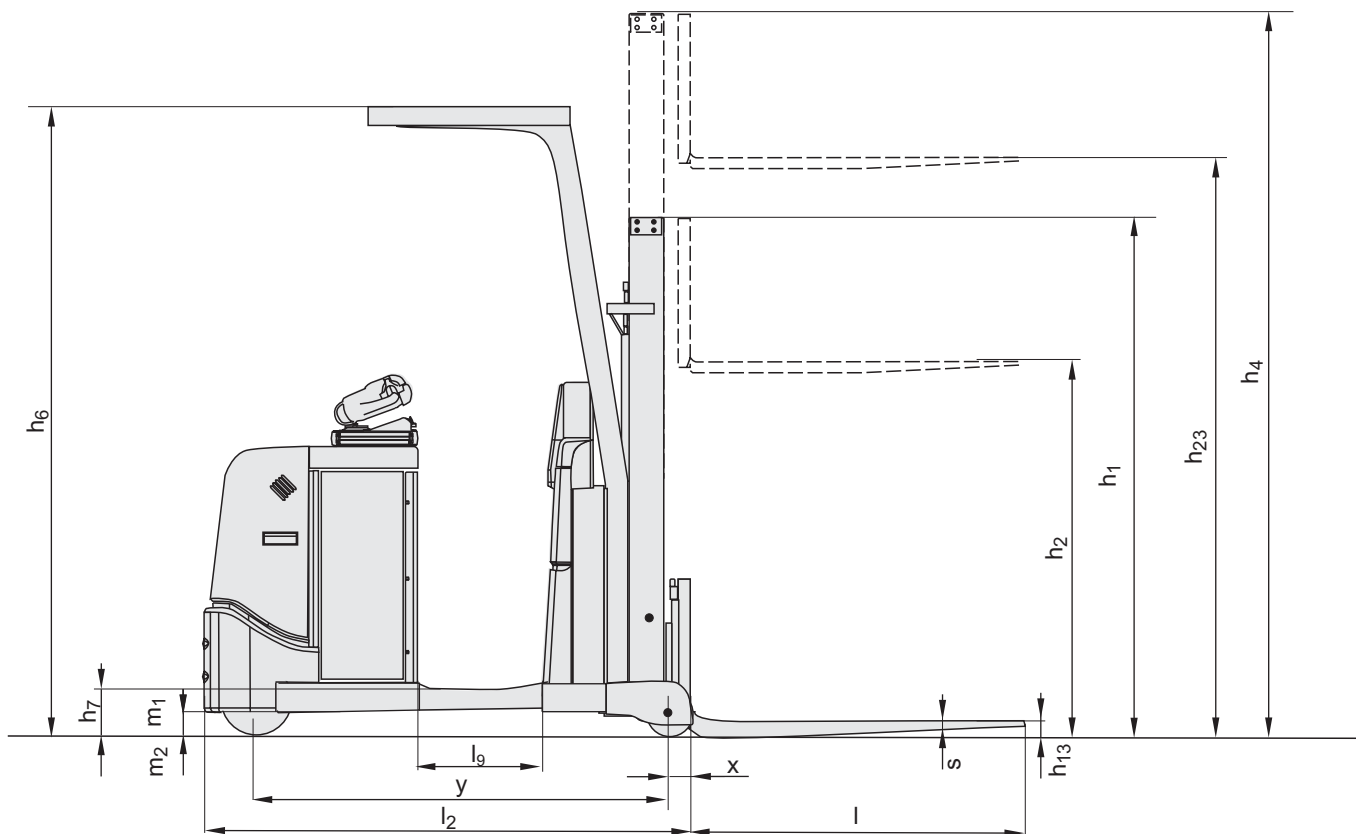



- The new E-MAN steering concept is ideally suitable for picking as well as for pallet handling applications. Light, one hand operation increases the flexibility for the driver and at the same time simplifies driving in the fork direction.
- The new steering handle can easily be adjusted sideways. This optional feature is excellent when the driver wants to operate the truck while walking along it. Its flexible solution will also help the operator in difficult manoeuvring situations.
- The performance of the OSE120CB is first-rate. A travel speed of 12 km/h together with high acceleration increases the number of pick-ups. With our motor technology it is very easy to adjust top speed, acceleration and speed reduction to meet individual requirements.
- The BT POWERDRIVE system provides reliability and simplicity. CAN-bus technology means fewer parts and reliable transmission of data. A PIN code start up procedure offers higher operational safety by stopping unauthorised driving.
- The forks can be elevated to ensure an ergonomic working position. It is also possible to stack pallets up to maximum 4.1m lift height. Since the design is without any support arms the truck can easily operate closed pallets.

Truck features	OSE120CB
BT Powerdrive System	S
High performance models	S
Controls and instrument	
Adjustable BT Control console	O
Fingertip controls	S
Information display	S
Power/Electronic steering	S
Driving features	
200° steering	S
Automatic deceleration	S
Electronic regenerative brakes	S
Safety features	
2-step lowering system	O
BT Access Control	S
Clear-view overhead guard	S/O
Driver detection system	S
Programmable performance	S
Drivers compartment features	
Folding seat	O
Lift-/lowering button on backrest	O
Low step-in	S
PC Bracket	O
Storage compartments	S
Writing table	O
Maintenance features	
Easy access for maintenance	S
Fault diagnosis facility	S
Battery management features	
Battery change facility	O
Battery status indicator	S

S = Standard feature

O = Optional feature

— = Not available

BT  
 SE-595 81 Mjölby Sweden  
 Tel: +46 (0)142 860 00  
 Fax: +46 (0) 142 866 00  
 Email: info@bt-forklifts.com  
 www.bt-forklifts.com

