



The LRE200 truck represents the highest standards for efficiency in long distance load transportation. The truck has been developed with a focus on driver ergonomics, recognizing its impact on overall productivity. Rated capacity of 2000kg.



Technical Details		LRE200
Power unit		electrical, battery
Operating type		ride on
Rated capacity	kg	2000
Load centre	mm	600
Weight without battery, l=1150 mm	kg	750
Max. axle load castor/drive wheels, without/with rated load	kg	1045/1490
Max. axle load fork wheels, without/with rated load	kg	305/1860
Wheel type, front/rear		polyurethane
dimension, drive wheel	mm	Ø 250x105
dimension, castor wheels	mm	Ø 150x50
dimension, fork wheels, bogie	mm	Ø 80x75
Travel speed, without/with rated load	km/h	10,1/8,6
Service brake		hydraulic
Parking brake		mechanical
Lifting time, without/with rated load	s	2,2/2,7
Lowering time, without/with rated load	s	4,5/3,1
Gradient, without/with rated load	%	15/8
Drive motor/Intermittent rating	kW/%	2,6/60
Lift motor/Intermittent rating	kW/%	2,0/10
Battery weight, min./max.	kg	382/490
Battery, min./max.	V/Ah	24/375—620
Steering system		electronic
Speed control, number of steps		transistor, stepless
Number of steering wheel turnings		6 or 6—12

Dimensions, mm		LRE200
x	Front axle to fork front face, fork raised/lowered	956/899
h <sub>13</sub>	Height of lowered fork	85
h <sub>6</sub>	Height of truck. min./max.	1425/1980
h <sub>7</sub>	Height of driver's seat	900—980
l <sub>2</sub>	Truck length incl. back of fork	974
b <sub>1</sub>	Chassis, width	1020
e	Fork width	180
l	Fork length	1150
b <sub>5</sub>	Width across fork	450/520/570/685
m <sub>1</sub>	Floor clearance	28
W <sub>a</sub>	Turning radius, fork raised	1910
h <sub>3</sub>	Lift height	205

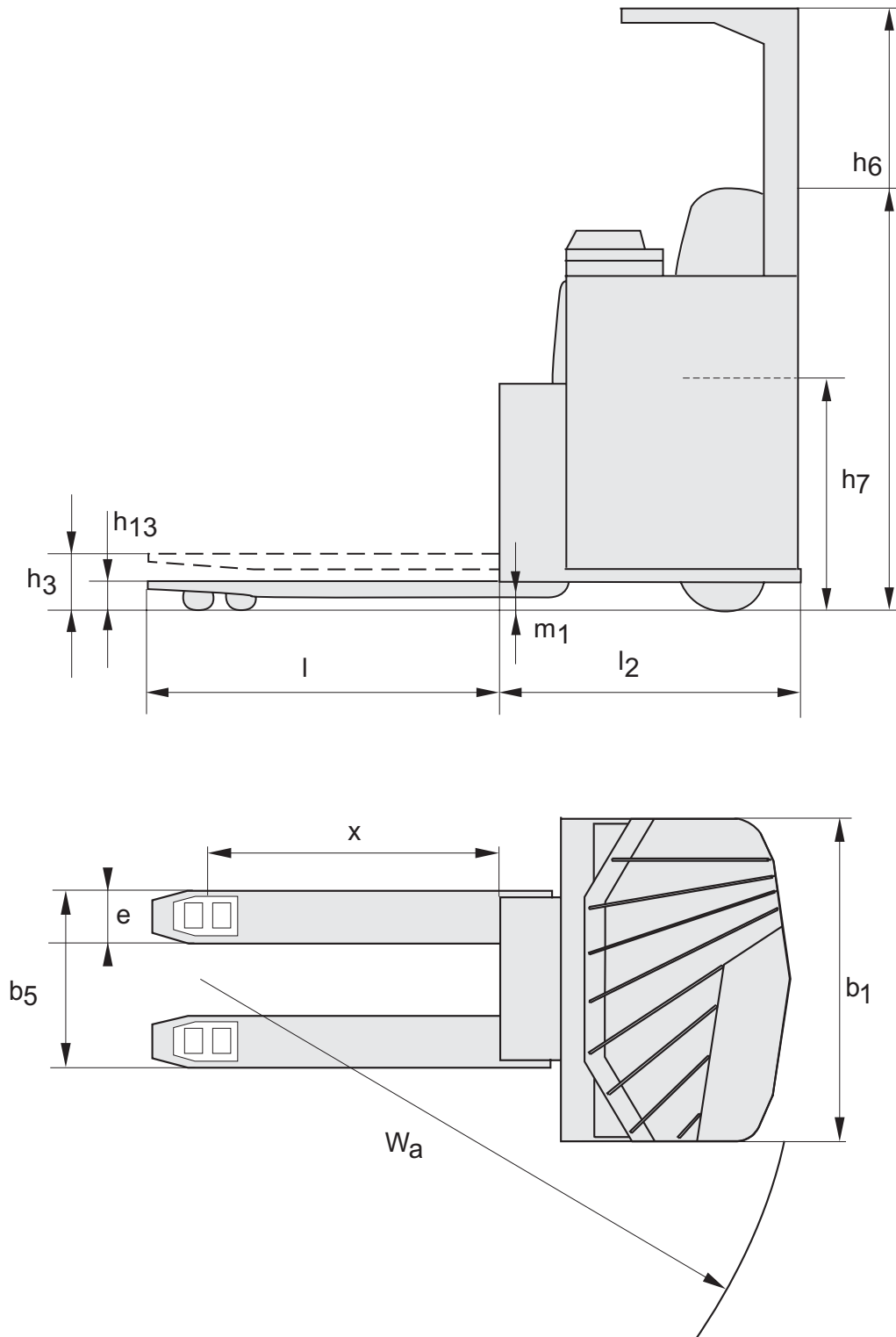



- Electronic steering is a standard feature. The traditional steering wheel is replaced by a small “spinner wheel” that provides fingertip control for the highest levels of manoeuvrability.
- The driver’s cab provides total protection for the operator, and comfort is assured with fully adjustable seat and pedal positions.
- The pedals are laid out as in a car to ensure ease and familiarity in operation.
- Controls and instruments are well laid-out, and include a combined battery condition indicator/hour meter.
- The battery is easily changed in multishift operation via a built-in rollerbed system.
- The machine is based upon BT’s advanced reach truck design, providing excellent servicing features and easy access to all parts and components.

Truck features	LRE200
Bogie fork wheels	S
Controls and instruments	
Adjustable BT Control console	S
Information display	S
Power/Electronic steering	S
Driving features	
Electronic braking system	S
Safety features	
Driver detection system	S
Emergency cut-off	S
Parking brake	S
Clear-view overhead guard	O
Load support	O
Drivers compartment features	
Adjustable seat	S
Adjustable steering wheel	S
Maintenance features	
Easy access for maintenance	S
Fault diagnosis facility	S
History fault log	S
Battery management features	
Battery status indicator	S
Sideways battery change	S

S = Standard feature

O = Optional feature

— = Not available