



Designed for easy operation in shops, factories and small stores these Ixion's are fully powered stackers with high performance but minimum size. Flexible and easily driven trucks equipped with elevating support arms that allow use on gradients or uneven surfaces.



Technical Details		SWE120L <sup>1)</sup>	SWE160D <sup>2)</sup>
Rated capacity	kg	1200	1025 <sup>3)</sup>
Rated capacity, support arm lift	kg	1600	1600
Rated capacity, fork and support arm lift	kg	—	800 + 800
Load centre	mm	600	600
Max. axle load drive wheel, without/with rated load/ 1600 kg on support arms	kg	345/345/345	345/345/345
Max. axle load support arm wheels, without/with rated load/ 1600 kg on support arms	kg	270/1310/1640	220/1052/1515
Max. axle load castor wheels, without/with rated load/ 1600 kg on support arms	kg	355/520/590	328/520/633
Travel speed, without/with 750 kg/with rated load	km/h	6.0/6.0/5.0	6.0/6.0/5.0
Lift speed, without/with rated load	m/s	0.19/0.10	0.19/0.11
Lowering speed, electric, without/with rated load	m/s	0.15/0.19	0.15/0.19
Lowering speed, mechanical, without/with rated load	m/s	0.15/0.19	0.15/0.19
Gradient, without/with rated load	%	12/10 <sup>4)</sup>	12/10 <sup>4)</sup>
Service-/parking brake		electromagnetic	electromagnetic
Drive motor/Intermittent rating	kW/%	1.2/60	1.2/60
Lift motor/Intermittent rating	kW/%	2.2/5.0	2.2/5.0
Steering system		steering arm	steering arm
Speed control		BT Powerdrive	BT Powerdrive
Steering arc	°	208	208

Dimensions, mm		SWE120L <sup>1)</sup>	SWE160D <sup>2)</sup>
x	Back of fork to wheel centre, bogie/single	858/858 <sup>5)</sup>	959/959 <sup>5)</sup>
y	Wheel base	1502 <sup>5)</sup>	1602 <sup>5)</sup>
	Drive wheel, Powerfriction <sup>6)</sup>	Ø 215x70	Ø 215x70
	Castor wheels, Vulkollan	Ø 125x50	Ø 125x50
	Support arm wheels, bogie or single, Vulkollan	Ø 80x75	Ø 80x75
h <sub>5</sub>	Support arm lift height	200	200
h <sub>7</sub>	Platform height	150	150
l <sub>4</sub>	Platform length	400	400
h <sub>14</sub>	Height of handle in neutral pos., without/with platform	1365/1415	1365/1415
h <sub>13</sub>	Height of fork, support arms lowered/raised	90/210	90/210
b <sub>1</sub>	Chassis, width	800	770
l <sub>2</sub>	Truck length incl. fork face, without/with platform up/down	796/888/1262 <sup>7)</sup>	813/905/1279 <sup>7)</sup>
s	Fork thickness	60	60
e	Fork width	182	182
l	Fork length	1150/1000	1150/1000
b <sub>5</sub>	Width across fork	570	570
m <sub>1</sub>	Floor clearance, min./max.	17/137	17/137
A <sub>st</sub>	Aisle width, without/platform up/down	2215/2311/2680 <sup>7)</sup>	2220/2318/2688 <sup>7)</sup>
W <sub>a</sub>	Turning radius, without/with platform up/down	1673/1769/2138 <sup>7)</sup>	1779/1876/2246 <sup>7)</sup>

Mast, SWE120L			Simplex		Duplex Tele				Duplex Hi-Lo			
<b>h<sub>23</sub></b>	<b>Total lift height</b>	<b>mm</b>	<b>1400 <sup>8)</sup></b>	<b>1700 <sup>8)</sup></b>	<b>2700</b>	<b>2900</b>	<b>3300</b>	<b>3700</b>	<b>2700</b>	<b>2900</b>	<b>3300</b>	<b>3700</b>
h <sub>1</sub>	Height of mast, min.	mm	1820 <sup>8)</sup>	2125 <sup>8)</sup>	1839 <sup>8)</sup>	1945 <sup>8)</sup>	2144 <sup>8)</sup>	2344 <sup>8)</sup>	1839 <sup>8)</sup>	1945 <sup>8)</sup>	2144 <sup>8)</sup>	2344 <sup>8)</sup>
h <sub>2</sub>	Free lift	mm	1400 <sup>8)</sup>	1700 <sup>8)</sup>	160 <sup>8)</sup>	160 <sup>8)</sup>	160 <sup>8)</sup>	160 <sup>8)</sup>	1400 <sup>8)</sup>	1500 <sup>8)</sup>	1700 <sup>8)</sup>	1900 <sup>8)</sup>
h <sub>4</sub>	Height of mast, max.	mm	1820 <sup>8)</sup>	2125 <sup>8)</sup>	3110	3320	3720	4120	3110	3320	3720	4120
	Weight without battery <sup>9)</sup>	kg	677	688	748	786	803	820	748	786	803	820
	Battery (5h discharge), min./max.	Ah	165/300									
	Battery weight, min./max.	kg	150/260									

Mast, SWE160D <sup>8)</sup>			Duplex Tele		
<b>h<sub>23</sub></b>	<b>Total lift height</b>	<b>mm</b>	<b>1700</b>	<b>1900</b>	<b>2100</b>
h <sub>1</sub>	Height of mast, min.	mm	1330	1430	1530
h <sub>2</sub>	Free lift	mm	160	160	160
h <sub>4</sub>	Height of mast, max.	mm	2110	2310	2510
	Weight without battery <sup>9)</sup>	kg	655	665	675
	Battery (5h discharge), min./max.	Ah	165/195	225/300	225/300
	Battery weight, min./max.	kg	150/200	200/260	200/260

- 1) Data is based on l = 1150 mm, h<sub>23</sub> = 2700 mm, without platform, medium battery compartment and lowered support arms
- 2) Data is based on l = 1150 mm, h<sub>23</sub> = 1700 mm, without platform, medium battery compartment and lowered support arms
- 3) Max. load weight 1200 kg up to 1900 mm lift height
- 4) Due to motor characteristics. Please ask technical support regarding driving on ramps and gradients
- 5) -64 mm with raised support arms
- 6) Other alternatives available
- 7) Large battery compartment = +52 mm
- 8) +120 mm with raised support arms
- 9) Platform weight 30 kg

Truck performance and dimensions are nominal and subject to tolerances.  
BT Products AB products and specifications are subject to change without notice.  
All data is based on VDI 2198.

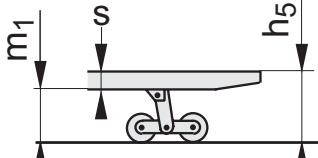
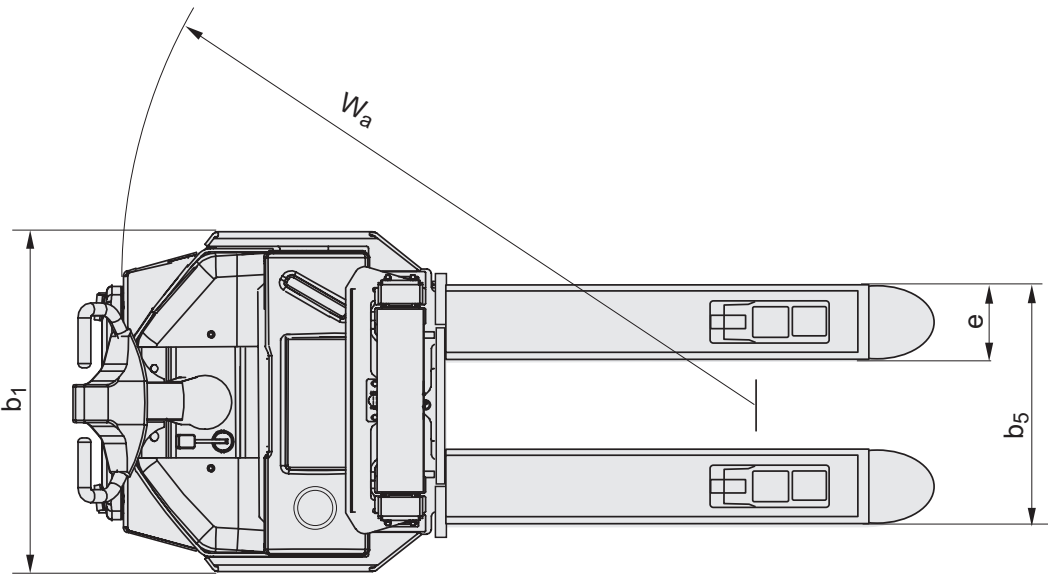
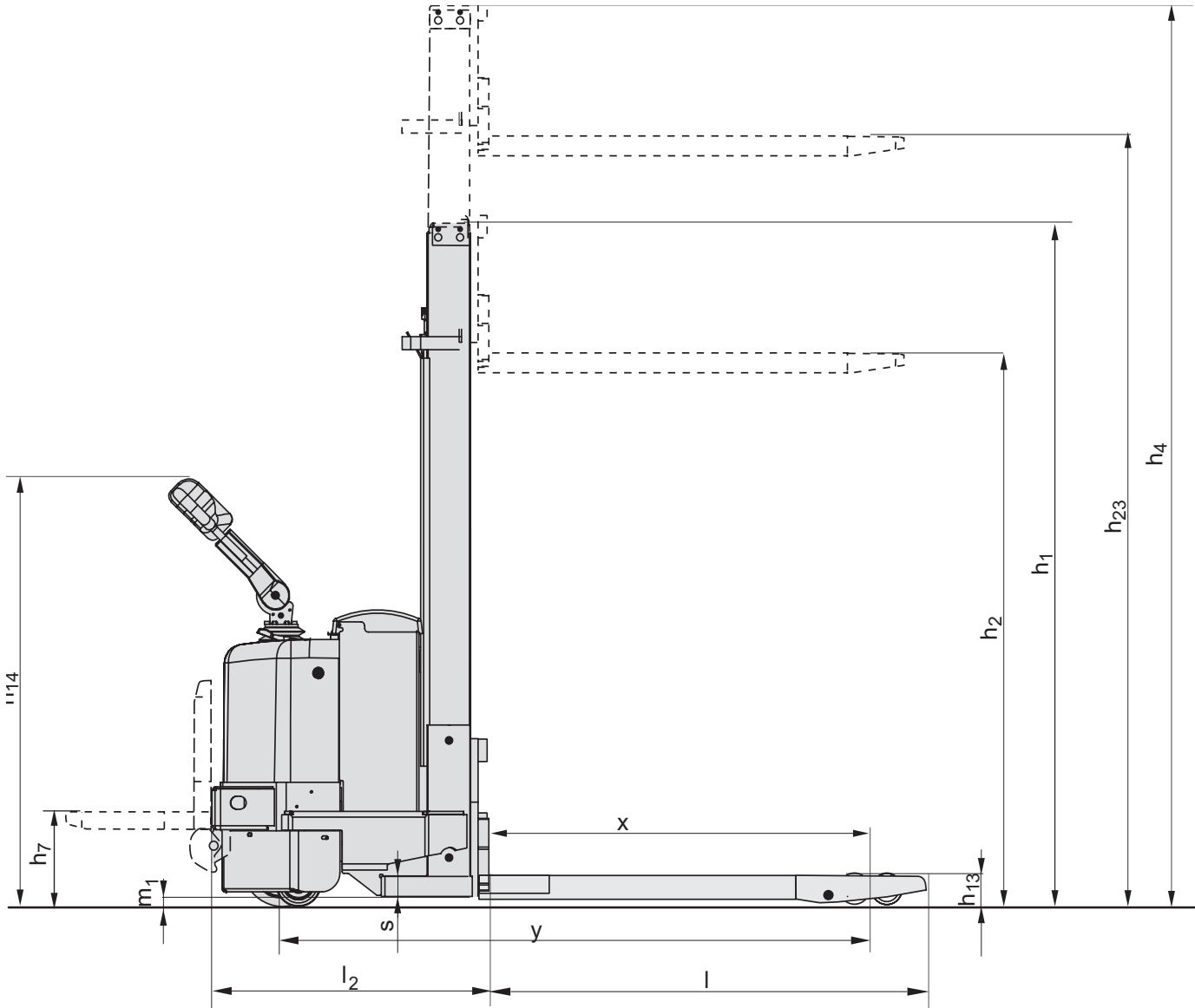



- These trucks are suitable for loading/unloading operations in combination with stacking.  
The SWE160D can also be used for double pallet handling (800 + 800 kg).
- The elevating support arms give higher floor clearance for safer operations.
- The comfortable steering arm, with its modern design, facilitates one hand operation. The lift, lowering and driving functions are ergonomically placed on the steering arm and can be operated by finger tip force.
- Individual driver parameters, top speed, acceleration and automatic speed reduction, to meet driver skills can be programmed via the key pad (no tool needed).
- The BT Powerdrive system provides reliability and simplicity. Can-bus technology means fewer parts and reliable transmission of data. A Pin code start up procedure offers higher operational safety by stopping unauthorised driving.
- The castor wheels fully rotate within the profile of the truck ensuring safety for the operator, and easy turnings in the tightest situations.



Truck features	SWE120L	SWE160D
Bogie fork wheels	S	S
BT Powerdrive System	S	S
Elevating support arms	S	S
Spring-loaded drive wheel	S	S
<b>Controls and instrument</b>		
Information display	S	S
Temporary speed reduction (turtle button)	O	O
Tiller arm steering	S	S
<b>Driving features</b>		
208° steering	S	S
Electronic braking system	S	S
Electronic speed control	S	S
Flip-down driver platform	O	O
<b>Safety features</b>		
Automatic parking brake	S	S
Clear-view mast	S	S
Emergency collision button	S	S
Programmable performance	S	S
<b>Drivers compartment features</b>		
Storage compartments	S	S
<b>Maintenance features</b>		
Easy access for maintenance	S	S
<b>Battery management features</b>		
Built-in charger	O	O
Heavy duty battery compartments	O	O
Sideways battery change	O	O

S = Standard feature

O = Optional feature

— = Not available